



## Electrak<sup>®</sup> 050 – Technical Features



### Standard Features

- Designed for office or medical applications
- Small, quiet and lightweight
- Short retracted length
- Low cost
- Durable and corrosion free plastic housing
- Color molded into the plastic, no painting required
- Maintenance free
- Internally restrained extension tube
- Estimated life is minimum 40000 cycles

### General Specifications

Screw type	worm
Nut type	lead
Manual override	no
Anti-rotation	yes
Static load holding brake	no (self-locking)
Safety features	internal limit switches overload clutch auto reset thermal switch
Electrical connections	cable with flying leads or connector
Compliances	CE

### Optional Mechanical Features

Cross hole orientation

### Optional Electrical Features

End of stroke limit switches with dynamic braking

Potentiometer feedback

# Electrak<sup>®</sup> 050 – Technical Specifications

Mechanical Specifications		
Max. static load <sup>(1)</sup>	[N (lbf)]	
DExx17W41		1020 (224)
DExx17W42		550 (120)
DExx17W44		280 (60)
Max. dynamic load (Fx)	[N (lbf)]	
DExx17W41		510 (112)
DExx17W42		275 (60)
DExx17W44		140 (30)
Speed @ no load/max. load	[mm/s (in/s)]	12/9 (0.5 /0.35) 24/18 (0.9/0.7) 48/37 (1.9/1.5)
Min. ordering stroke (S) length	[mm]	25
Max. ordering stroke (S) length	[mm]	200
Ordering stroke length increments	[in]	25
Operating temperature limits	[°C (F)]	-30 – 80 (-22 – 176)
Full load duty cycle @ 20 °C (70 °F)	[%]	25
End play, maximum	[mm (in)]	1.5 (0.06)
Restraining torque	[Nm (lbf-in)]	0
Protection class - static		IP56
Salt spray resistance	[h]	96

Electrical Specifications		
Available input voltages	[Vdc]	12, 24, 36
Input voltage tolerance	[%]	± 10
Current draw @ no load/max. load <sup>(1)</sup>	[A]	
DE12-17W41		1.4/3.8
DE12-17W42		0.7/1.9
DE12-17W44		1.2/3.8
DE24-17W41		0.6/1.8
DE24-17W42		1.4/3.8
DE24-17W44		0.7/1.9
Cable lengths, standard <sup>(2)</sup>	[mm (in)]	150 (6.0)
Cable diameter	[mm (in)]	13 (0.5)
Cable leads cross section	[mm <sup>2</sup> (AWG)]	1 (18)

(1) For current draw for 36 Vdc input voltage models - contact customer support.

(2) The same cable is used both for the input voltage and the feedback signals.



# Electrak<sup>®</sup> 050 – Dimensions

Dimensions	Projection
mm [inch]	

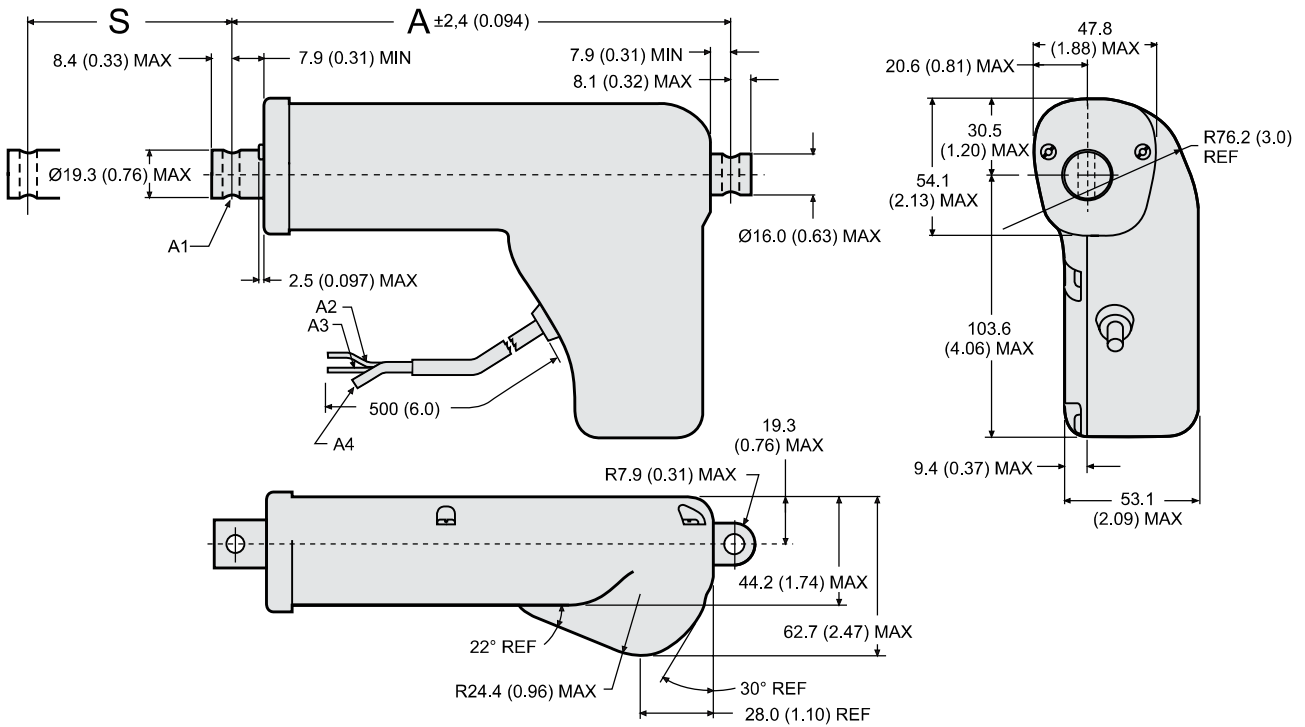

Note: see 3D models for all available adapter options

S: stroke (tolerances: 17W41 = ± 3.23 mm (0.127 in), 17W42 = ± 4.25 mm (0.167 in), 17W44 = ± 5.26 mm (0.207 in))

A: retracted length

A1: Shown are Ø 6 mm +0.15/-0 (0.236 in +0.006/-0) mounting cross holes (2 x) in standard position.

A2: red lead

A3: yellow lead

A4: vent tube Ø 3 mm (0.188 in)

Stroke, Retracted Length and Weight Relationships									
Ordering stroke (S)	[in]	1	2	3	4	5	6	7	8
Retracted length (A)	[mm]	114.2	139.2	164.2	189.2	214.2	239.2	264.2	289.2
	[in]	4.496	5.480	6.465	7.449	8.433	9.417	10.402	11.386
Add on length for option 0.25 inch fork front adapter	[mm]	16.3							
	[in]	0.64							
Add on length for option potentiometer	[mm]	31.5							
	[in]	1.24							
Weight	[kg]	0.59	0.64	0.69	0.73	0.78	0.82	0.87	0.91
	[lbf]	1.30	1.41	1.52	1.61	1.72	1.81	1.92	2.01
Add on weight for option potentiometer	[kg]	0.10							
	[lbf]	0.22							

\* 8 inch stroke not possible with potentiometer (PO, MP, PF options)

# Electrak® 050 – Performance Diagrams

Speed and Current vs. Load

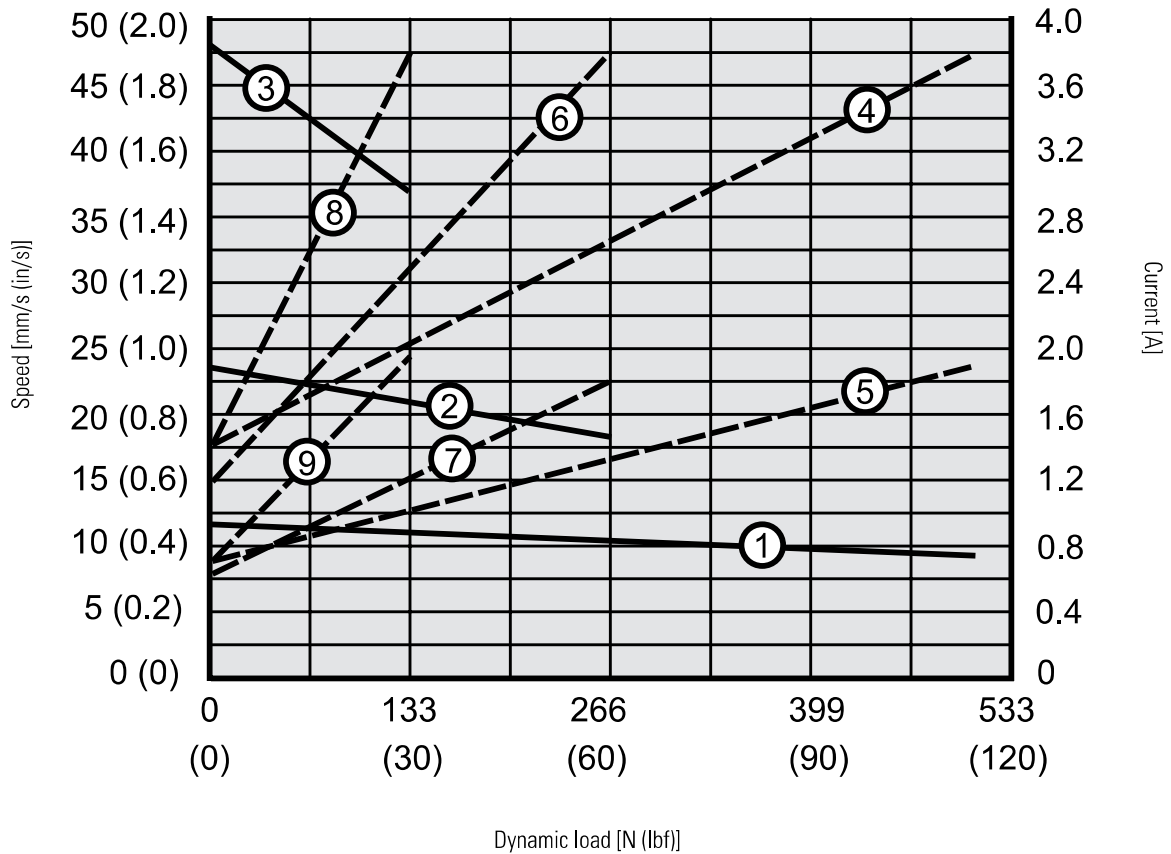

Speed

- 1: DExx-17W41 (510 N (112 lbf))
- 2: DExx-17W42 (275 N (60 lbf))
- 3: DExx-17W44 (140 N (30 lbf))

Current

- 4: DE12-17W41 (12 Vdc, 510 N (112 lbf))
- 5: DE24-17W41 (24 Vdc, 510 N (112 lbf))
- 6: DE12-17W42 (12 Vdc, 275 N (60 lbf))
- 7: DE24-17W42 (24 Vdc, 275 N (60 lbf))
- 8: DE12-17W44 (12 Vdc, 140 N (30 lbf))
- 9: DE24-17W44 (24 Vdc, 140 N (30 lbf))



## Electrak® 050 – Ordering Key

Ordering Key							
1	2	3	4	5	6	7	8
DE12-	17W41-	02	NN	HH	N-	C	A
<b>1. Model and input voltage</b> DE12- = Electrak 050, 12 Vdc DE24- = Electrak 050, 24 Vdc DE36- = Electrak 050, 36 Vdc	<b>2. Dynamic load capacity</b> 17W41 - = 510 N (112 lbf) 17W42 - = 275 N (60 lbf) 17W44 - = 140 N (30 lbf)	<b>3. Ordering stroke length</b> 01 = 1 inch (25.4 mm) 02 = 2 inch (50.8 mm) 03 = 3 inch (76.2 mm) 04 = 4 inch (101.6 mm) 05 = 5 inch (127.0 mm) 06 = 6 inch (152.4 mm) 07 = 7 inch (177.8 mm) 08 = 8 inch (203.2 mm)	<b>4. Options</b> NN = no option FN = end-off-stroke limits switches NP = potentiometer FP = end-off-stroke limits switches + potentiometer	<b>5. Cross-hole orientation</b> HH = standard cross-hole orientation in both ends MH = cross-hole rotated 90° in both ends	<b>6. Color of housing</b> N- = black	<b>7. Type of connector</b> C = Packard Electric Pack-Con D = no connector (flying leads)	<b>8. Front adapter</b> A = cross-hole 0.25 inch B = fork 0.25 inch

# Electrak<sup>®</sup> 050 – Electrical Connections

Without Option		
Actuator supply voltage	[Vdc]	
DE12		12
DE24		24
DE36		36

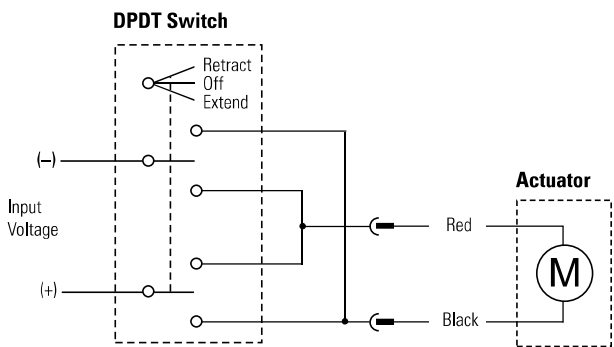

Connect the black lead to positive and red to negative to extend the actuator. Change polarity to retract the actuator.

Option Potentiometer		
Actuator supply voltage	[Vdc]	
DE12		12
DE24		24
DE36		36
Potentiometer type		wire-wound
Potentiometer max. input voltage	[Vdc]	32
Potentiometer max. power	[W]	2
Potentiometer linearity	[%]	± 0.25
Potentiometer output resolution	[ohm/mm]	
DExx-17W41		22.0
DExx-17W42		21.9
DExx-17W44		21.2

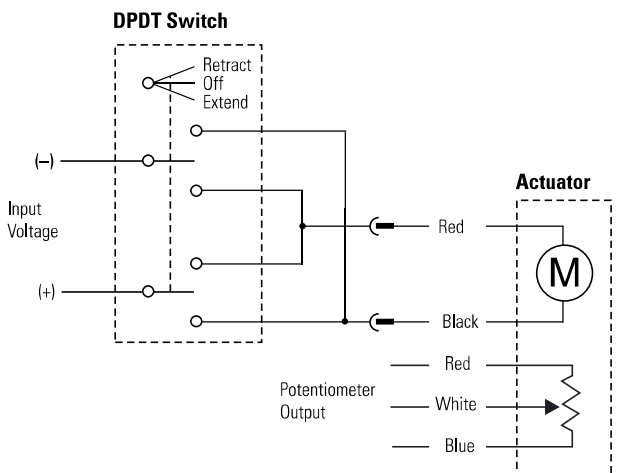

Connect the black lead to positive and red to negative to extend the actuator. Change polarity to retract the actuator. The potentiometer output has 0 ohm between white and blue when the actuator is fully retracted.