



Electrak[®] MD – Technical Features



General Specifications	
Screw type	acme
Nut type	lead
Manual override	no
Anti-rotation	yes
Static load holding brake	no (self-locking)
Electrical connections	cable with flying leads
Compliance	CE, RoHs, REACH, ISO 13766

Standard Features

- Best-in-class power density
- Onboard electronics, including versions with SAE J1939 CAN bus or CANopen CAN bus
- Suitable for pneumatic and hydraulic-to-electric application conversions
- Designed and tested to meet the toughest environmental demands
- Reliable and maintenance free

Optional Features	
Mechanical options	Multiple cable length options
	Alternative adapter orientation
Control options (see page 111)	End-of-stroke limit switches
	Analog position feedback
	Low-level signal motor switching
	SAE J1939 CAN bus
	CANopen CAN bus

Control Option Safety Features

	Control Option							
	XXX	XXP	EXX	EXP	LXX	LXP	CNO	COO
Dynamic braking	no	no	yes	yes	yes	yes	yes	yes
End-of-stroke protection	yes	yes	yes	yes	yes	yes	yes	yes
Overload protection	no	no	yes	yes	yes	yes	yes	yes
Temperature monitoring	no	no	yes	yes	yes	yes	yes	yes
Temperature compensation	no	no	yes	yes	yes	yes	no	no
Voltage monitoring	no	no	yes	yes	yes	yes	yes	yes
PWM voltage compatible	yes	yes	no	no	no	no	no	no

Electrak[®] MD – Technical Specifications

Mechanical Specifications		
Max. static and dynamic load (Fx)	[N (lbs)]	
MDxxA025		250 (56)
MDxxA050		500 (112)
MDxxA100		1000 (225)
MDxxA200		2000 (450)
Speed @ no load/max. load	[mm/s (in/s)]	
MDxxA025		52/43.8 (2.04/1.72)
MDxxA050		28/18.5 (1.1/0.73)
MDxxA100		14.5/11 (0.57/0.43)
MDxxA200		7/5.4 (0.28/0.21)
Min. ordering stroke (S) length	[mm]	50
Max. ordering stroke (S) length	[mm]	300
Ordering stroke length increments	[mm]	50
Operating temperature limits	[°C (F)]	-40–85 (-40– 185)
Full load duty cycle @ 25 °C (77 °F)	[%]	25
End play, maximum	[mm (in)]	1.2 (0.047)
Restraining torque	[Nm (lbs)]	0
Protection class - static		IP67/IP69K
Protection class - dynamic		IP66
Salt spray resistance	[h]	500

Electrical Specifications		
Available input voltages	[Vdc]	12, 24
Input voltage tolerance	[Vdc]	
MD12 (12 Vdc input voltage)		9 - 16
MD24 (24 Vdc input voltage)		18 - 32
Current draw @ no load/max. load	[A]	
MD12A025		1.2/5.2
MD24A025		0.6/2.6
MD12A050		1.4/6.2
MD24A050		0.7/3.1
MD12A100		1.2/5.2
MD24A100		0.6/2.6
MD12A200		1.4/6.2
MD24A200		0.7/3.1
Motor leads cross section	[mm ² (AWG)]	0.75 (18)
Signal leads cross section	[mm ² (AWG)]	0.35 (22)
Cable lengths, standard	[mm (in)]	300 (11.81) or 1000 (39.37)
Cable diameter	[mm (in)]	7.5 (0.3)

Actuator Weight [kg (lb)]

Ordering Stroke (S) [mm]					
50	100	150	200	250	300
1.1 (2.4)	1.2 (2.6)	1.3 (2.8)	1.4 (3.1)	1.5 (3.3)	1.6 (3.5)



Electrak[®] MD – Ordering Key

Ordering Key								
1	2	3	4	5	6	7	8	9
MD12	A025-	0300	XXX	2	N	N	S	D
<p>1. Model and input voltage MD12 = Electrak MD, 12 Vdc MD24 = Electrak MD, 24 Vdc</p> <p>2. Screw type, dynamic load capacity A025- = acme screw, 250 N (56 lbs) A050- = acme screw, 500 N (112 lbs) A100- = acme screw, 1000 N (225 lbs) A200- = acme screw, 2000 N (450 lbs)</p> <p>3. Ordering stroke length ⁽¹⁾ 0050 = 50 mm 0100 = 100 mm 0150 = 150 mm 0200 = 200 mm 0250 = 250 mm 0300 = 300 mm</p> <p>4. Electrak Modular Control System options XXX = internal end-of-stroke limit switches XXP = XXX + analog (potentiometer) position output EXX = Electronic Monitoring Package EXP = EXX + analog (potentiometer) position output LXX = EXX + low-level signal motor switching LLX = LXX + end-of-stroke indication outputs LXP = LXX + analog (potentiometer) position output LLP = LXP + end-of-stroke indication outputs CNO = EXX + SAE J1939 CAN bus + open-loop speed control COO = EXX + CANopen CAN bus + open-loop speed control</p>				<p>5. Harness option 1 = 0.3 m long cable with flying leads 2 = 1 m long cable with flying leads</p> <p>6. Rear adapter option N = forked cross hole for 10 mm pin</p> <p>7. Front adapter option N = forked cross hole for 10 mm pin</p> <p>8. Adapter orientation S = standard M = 90° turned</p> <p>9. Connector option D = flying leads</p> <p>(1) Other stroke lengths available upon request. Please contact customer support.</p>				

Electrak[®] MD – Dimensions

Dimensions	Projection
mm [inch]	

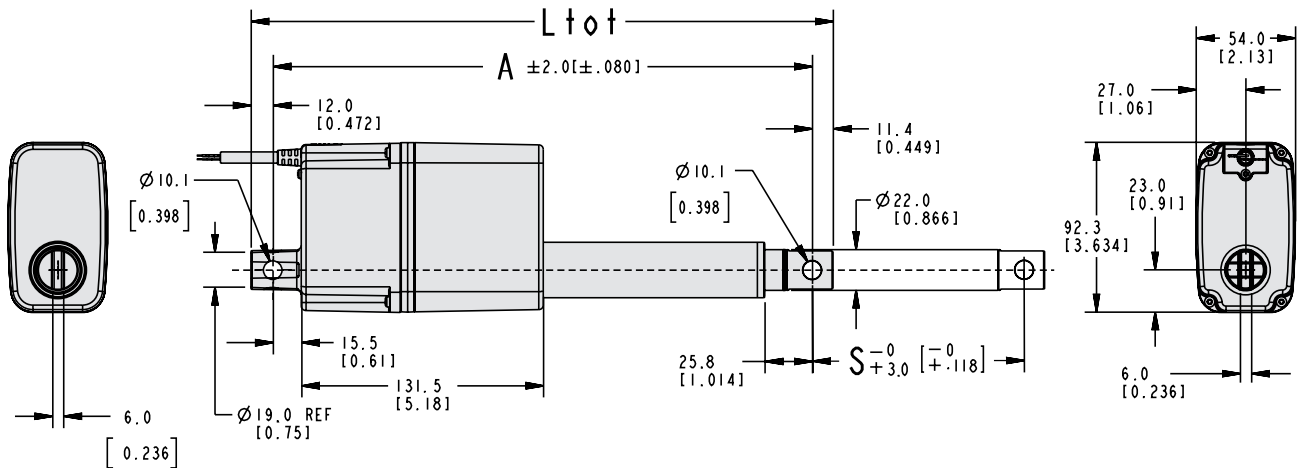

Note: All adapters shown in the standard orientation.

Ordering Stroke (S), Total Length (Ltot) and Retracted Length (A) Relationships

Standard Ordering Strokes (S)	[mm]	50, 100, 150, 200, 250, 300
Total Length (Ltot)	[mm]	$L_{tot} = A + 23.4$
Retracted Length (A)	[mm]	$A = S + 133.2$

Current for 24 Vdc Actuators [A]



Electrak[®] MD – Performance Diagrams

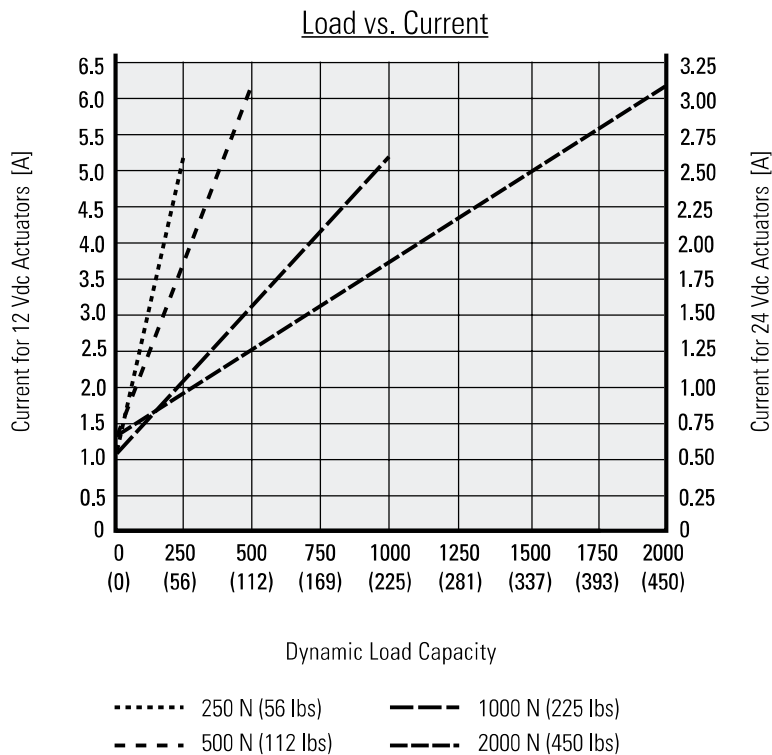
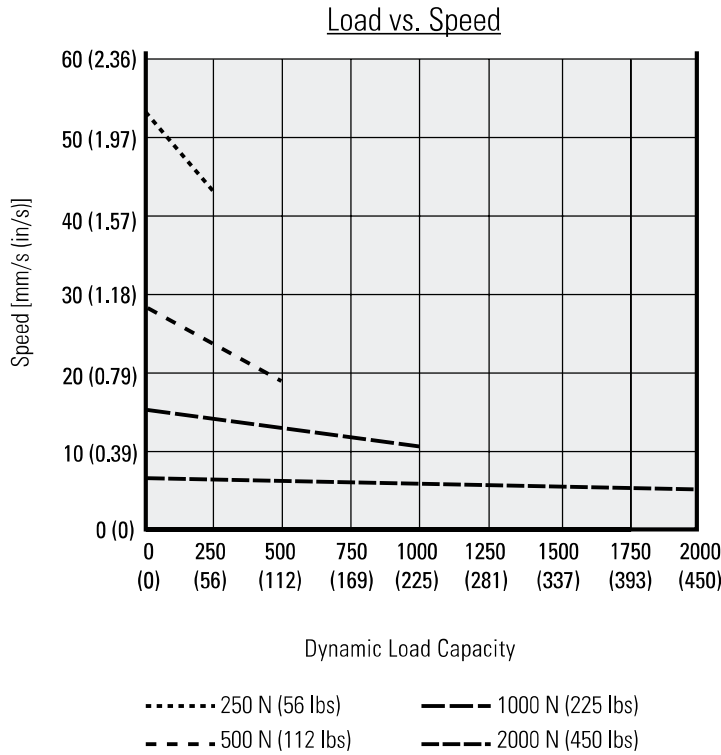

Note! Curves were generated at an ambient temperature of 21°C (70°F). Different ambient temperature and individual actuator characteristics can produce slightly different values.

Electrak[®] MD – Control Options

Control Option Type XXX		
Actuator supply voltage	[Vdc]	
MD12		9 - 16
MD24		18 - 32
Actuator current draw	[A]	see page 110

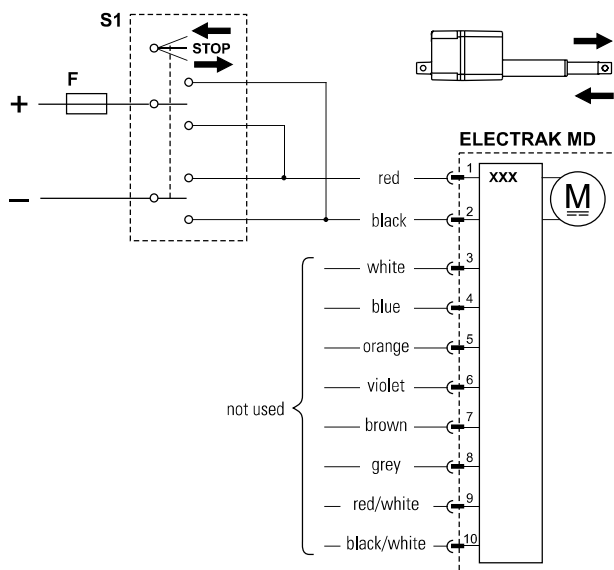

F Fuse
S1 Double pole double throw switch

With control option XXX, the polarity of the motor voltage is switched by a customer-supplied switch (switch, relay, etc.) to make the actuator extend or retract. The actuator will automatically stop when reaching the ends of stroke due to the built-in end- of-stroke limit switches. The switch, power supply, wiring and all other components must be able to handle the motor current for the actuator model and load being used, as well as the inrush current (up to three times the max. continuous current for the max. load being used for up to 150 milliseconds).

Control Option Type XXP		
Actuator supply voltage	[Vdc]	
MD12		9 - 16
MD24		18 - 32
Actuator current draw	[A]	see page 110
Potentiometer type		wire-wound
Potentiometer max. input voltage	[Vdc]	32
Potentiometer max. power	[W]	1
Potentiometer linearity	[%]	± 0.25
Potentiometer output resolution	[ohm/mm]	
MDxxA025, all strokes		16.67
MDxxA100, all strokes		16.67
MDxxA050, 50 - 250 mm stroke		33.33
MDxxA200, 50 - 250 mm stroke		33.33
MDxxA050, 300 mm stroke		16.67
MDxxA200, 300 mm stroke		16.67

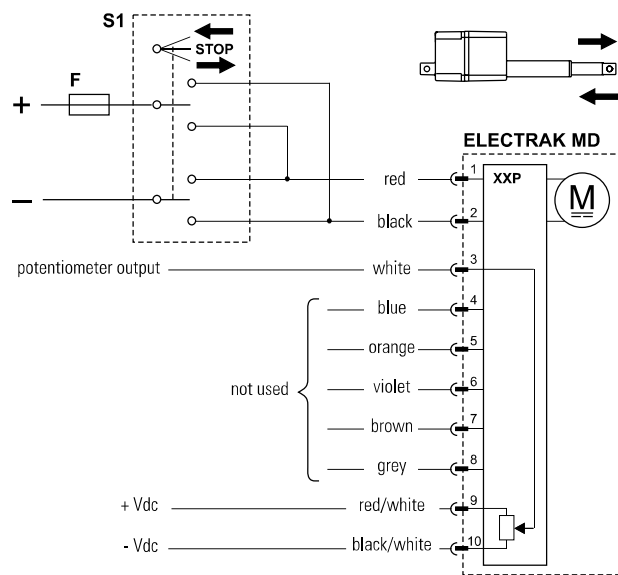

F Fuse
S1 Double pole double throw switch

Control option XXP works as option XXX but also has an analog (potentiometer) output that will provide feedback on the extension tube position.



Electrak[®] MD – Control Options

Control Option Type EXX		
Actuator supply voltage	[Vdc]	
MD12		9 - 16
MD24		18 - 32
Actuator current draw	[A]	see page 110

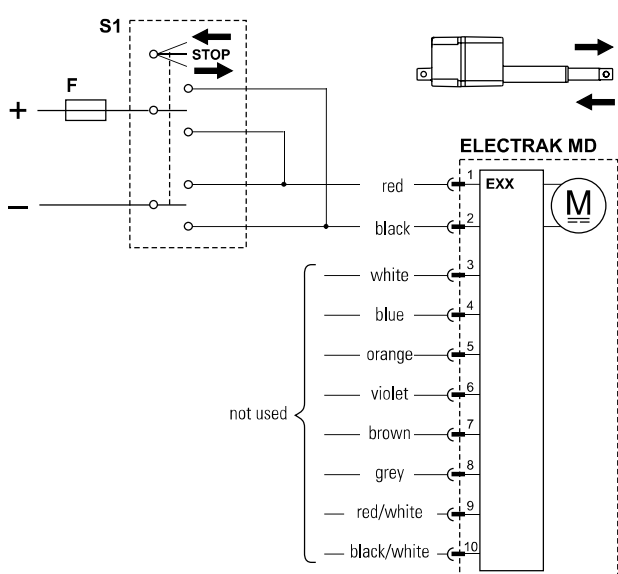

F Fuse
S1 Double pole double throw switch

Control option EXX contains all of the basic Electronic Monitoring Package features described on page six, guaranteeing safe operation of the actuator and equipment. With control option EXX, the polarity of the motor voltage is switched by a customer-supplied switch (switch, relay, etc.) to make the actuator extend or retract. The switch, power supply, wiring and all other components must be able to handle the motor current for the actuator model and load being used, as well as the inrush current (up to three times the max. continuous current for the max. load being used for up to 150 milliseconds).

Control Option Type EXP		
Actuator supply voltage	[Vdc]	
MD12		9 - 16
MD24		18 - 32
Actuator current draw	[A]	see page 110
Potentiometer type		wire-wound
Potentiometer max. input voltage	[Vdc]	32
Potentiometer max. power	[W]	1
Potentiometer linearity	[%]	± 0.25
Potentiometer output resolution	[ohm/mm]	
MDxxA025, all strokes		16.67
MDxxA100, all strokes		16.67
MDxxA050, 50 - 250 mm stroke		33.33
MDxxA200, 50 - 250 mm stroke		33.33
MDxxA050, 300 mm stroke		16.67
MDxxA200, 300 mm stroke		16.67

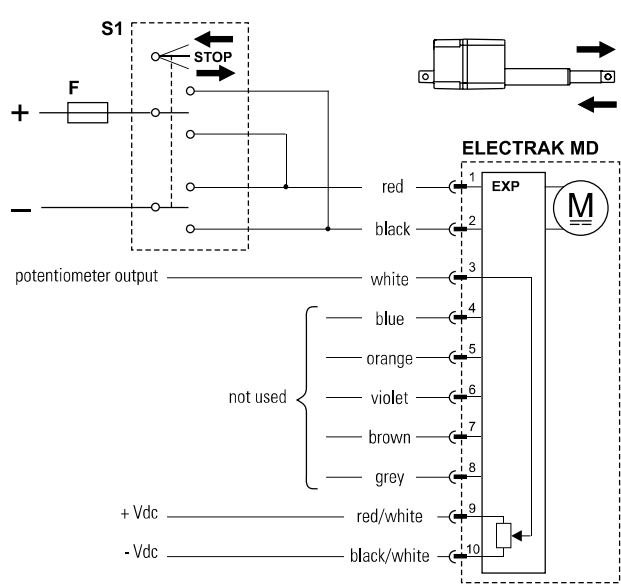

F Fuse
S1 Double pole double throw switch

Control option EXP works as option EXX but also has an analog (potentiometer) output that will provide feedback on the extension tube position.

Electrak[®] MD – Control Options

Control Option Type LXX		
Actuator supply voltage MD12 MD24	[Vdc]	9 - 16 18 - 32
Actuator current draw	[A]	see page 110
Extend / retract input voltage	[Vdc]	9 - 32
Extend / retract input current	[mA]	6 - 22

Control Option Type LLX		
Actuator supply voltage MD12 MD24	[Vdc]	9 - 16 18 - 32
Actuator current draw	[A]	see page 110
Extend / retract input voltage	[Vdc]	9 - 32
Extend / retract input current	[mA]	6 - 22
End-of-stroke outputs max. voltage	[Vdc]	32
End-of-stroke outputs max. current	[mA]	25

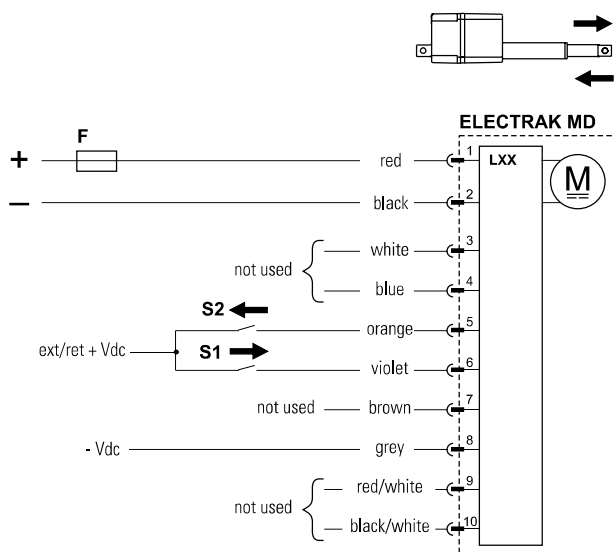

- F Fuse
- S1 Extend switch
- S2 Retract switch

Control option LXX has all the basic Electronic Monitoring Package features included in control option EXX, but the polarity of the motor voltage is switched by the onboard electronics instead. The customer-supplied switches used to command the actuator to extend or retract only need to handle low-level signals. However, the power supply and wiring that supply the actuator must be able to handle the motor current for the actuator model and load being used, as well as the inrush current (up to one and a half times the max. continuous current for the max. load being used for up to 150 milliseconds).

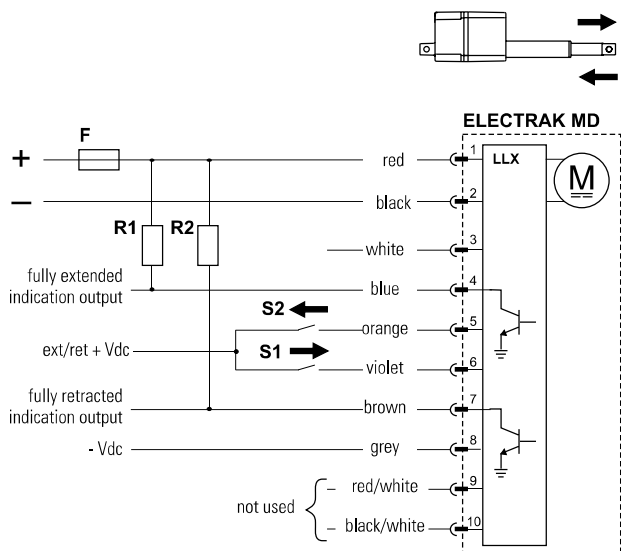

- F Fuse
- S1 Extend switch
- S2 Retract switch
- R1 Pull-up resistor
- R2 Pull-up resistor

Control option LLX works as option LXX but also has two end-of-stroke indication outputs that will signal when the actuator is fully extended or fully retracted. Since these outputs are current sinking open collector outputs, they will each require an external pull-up resistor to operate effectively.



Electrak[®] MD – Control Options

Control Option Type LXP		
Actuator supply voltage	[Vdc]	
MD12		9 - 16
MD24		18 - 32
Actuator current draw	[A]	see page 110
Potentiometer type		wire-wound
Potentiometer max. input voltage	[Vdc]	32
Potentiometer max. power	[W]	1
Potentiometer linearity	[%]	± 0.25
Potentiometer output resolution	[ohm/mm]	
MDxxA025, all strokes		16.67
MDxxA100, all strokes		16.67
MDxxA050, 50 - 250 mm stroke		33.33
MDxxA200, 50 - 250 mm stroke		33.33
MDxxA050, 300 mm stroke		16.67
MDxxA200, 300 mm stroke		16.67
Extend / retract input voltage	[Vdc]	9 - 32
Extend / retract input current	[mA]	6 - 22

Control Option Type LLP		
Actuator supply voltage	[Vdc]	
MD12		9 - 16
MD24		18 - 32
Actuator current draw	[A]	see page 110
Potentiometer type		wire-wound
Potentiometer max. input voltage	[Vdc]	32
Potentiometer max. power	[W]	1
Potentiometer linearity	[%]	± 0.25
Potentiometer output resolution	[ohm/mm]	
MDxxA025, all strokes		16.67
MDxxA100, all strokes		16.67
MDxxA050, 50 - 250 mm stroke		33.33
MDxxA200, 50 - 250 mm stroke		33.33
MDxxA050, 300 mm stroke		16.67
MDxxA200, 300 mm stroke		16.67
Extend / retract input voltage	[Vdc]	9 - 32
Extend / retract input current	[mA]	6 - 22
End-of-stroke outputs max. voltage	[Vdc]	32
End-of-stroke outputs max. current	[mA]	25

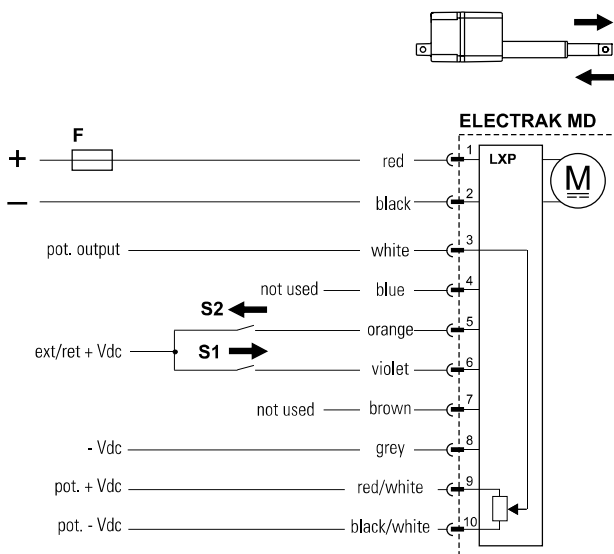

- F Fuse
- S1 Extend switch
- S2 Retract switch

Control option LXP works as option LXX but also has an analog (potentiometer) output that will provide feedback on the extension tube position.

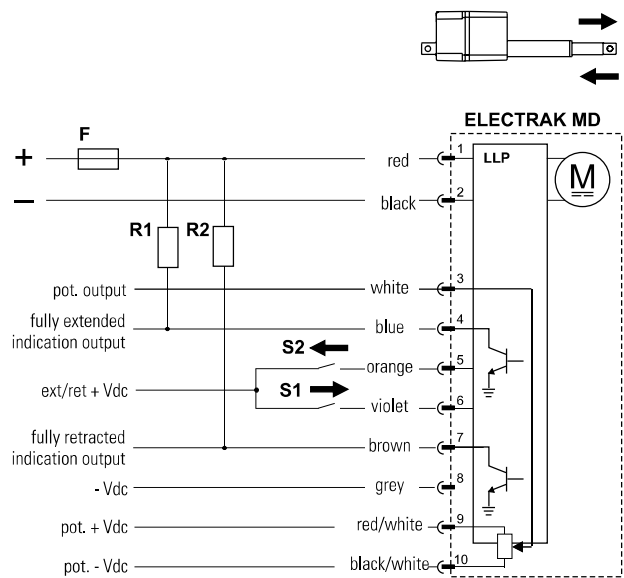

- F Fuse
- S1 Extend switch
- S2 Retract switch
- R1 Pull-up resistor
- R2 Pull-up resistor

Control option LLP works as option LLX but also has an analog (potentiometer) output that will provide feedback on the extension tube position.

Electrak[®] MD – Control Options

Control Option Type CNO and COO	
Actuator supply voltage [Vdc]	MD12 9 - 16 MD24 18 - 32
Actuator current draw [A]	see page 110
Command data includes:	<ul style="list-style-type: none"> • position • speed • current
Feedback data includes:	<ul style="list-style-type: none"> • position • speed • current • other diagnostic information
Manual extension/retraction input voltage [Vdc]	9 - 32
Manual extension/retraction input current [mA]	6 - 22

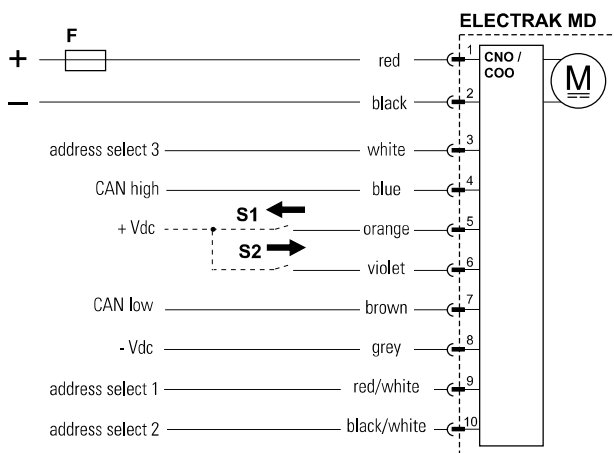
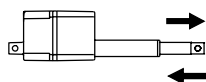

- F Fuse
- S1 Manual extension switch (optional)
- S2 Manual retraction switch (optional)

Control option CNO has a J1939 CAN bus control interface, COO has a CANopen control interface that control and monitor the actuator. Extend and retract commands are sent via CAN messages on the CAN low and CAN high pins. Address select 1, 2 and 3 pins can be used as a binary encoded decimal (BCD) adder to the default address. This can be used when multiple CAN actuators are on a single bus. The actuator can be manually forced to extend or retract by using pin 6 (violet wire) and 5 (orange wire).