



Max Jac[®] – Technical Features



Standard Features

- Designed for industrial applications
- Rugged aluminium housing with IP69K
- High efficiency
- Long life
- Hard coat anodizing for high corrosion resistance
- Virtually maintenance free
- Worm or ball screw models
- Non-contact analog position feedback signal

General Specifications

Screw type	worm or ball
Nut type	lead or ball
Manual override	no
Anti-rotation	no
Static load holding brake	no (self-locking)
worm screw models	no
ball screw models	no
Safety features	none
Electrical connections	flying leads or cable with AMP Superseal connector
Compliances	CE

Optional Electrical Features

Digital feedback

Compatible Controls

Contact customer support at www.thomsonlinear.com/cs

Max Jac[®] – Technical Specifications

Mechanical Specifications		
Max. static load ⁽¹⁾ MXxxW (worm screw) MXxxB (ball screw) ⁽²⁾	[N (lbf)]	2000 (450) 100 - 350 (22 - 79)
Max. dynamic load (Fx) MXxxW (worm screw) MXxxB (ball screw)	[N (lbf)]	500 (112) 800 (180)
Speed @ no load/max. load MXxxW (worm screw) MXxxB (ball screw)	[mm/s (in/s)]	33 / 19 (1.3 / 0.75) 60 / 30 (2.4 / 1.2)
Min. ordering stroke (S) length	[mm]	50
Max. ordering stroke (S) length MXxxW (worm screw) MXxxB (ball screw)	[mm]	200 300
Ordering stroke length increments	[mm]	50
Operating temperature limits	[°C (F)]	- 40 – 85 (- 40 – 185)
Duty cycle, maximum ⁽³⁾ MXxxW (worm screw) MXxxB (ball screw)	[%]	load dependent load dependent
End play, maximum	[mm (in)]	0.3 (0.012)
Restraining torque	[Nm (lbf-in)]	2 (1.48)
Protection class - static		IP66/IP69K
Salt spray resistance	[h]	500

(1) Max. static load at fully retracted stroke

(2) The static force (i.e. the back-driving force) for a ball screw unit varies and is dependent on the number of cycles it has been running and at which loads.

(3) See "Duty cycle vs. load" chart in the Glossary section.

Electrical Specifications		
Available input voltages	[Vdc]	12, 24
Input voltage tolerance	[%]	+15 / -10
Current draw @ no load/max. load MX12W (12 Vdc input, worm screw) MX24W (24 Vdc input, worm screw) MX12B (12 Vdc input, ball screw) MX24B (24 Vdc input, ball screw)	[A]	1.2/8.0 0.8/3.8 1.1/7.4 0.7/3.5
Inrush/stall current @ max. load MX12W (12 Vdc input, worm screw) MX24W (24 Vdc input, worm screw) MX12B (12 Vdc input, ball screw) MX24B (24 Vdc input, ball screw)	[A]	18.0 9.0 18.0 9.0
Cable lengths, standard ⁽¹⁾	[mm (in)]	300 (12), 1600 (63)
Cable diameter ⁽¹⁾	[mm (in)]	6.2 (0.244)
Cable leads cross section ⁽¹⁾	[mm ² (AWG)]	1 (18)

(1) The same cable is used both for the input voltage and the feedback signals.



Max Jac[®] – Dimensions

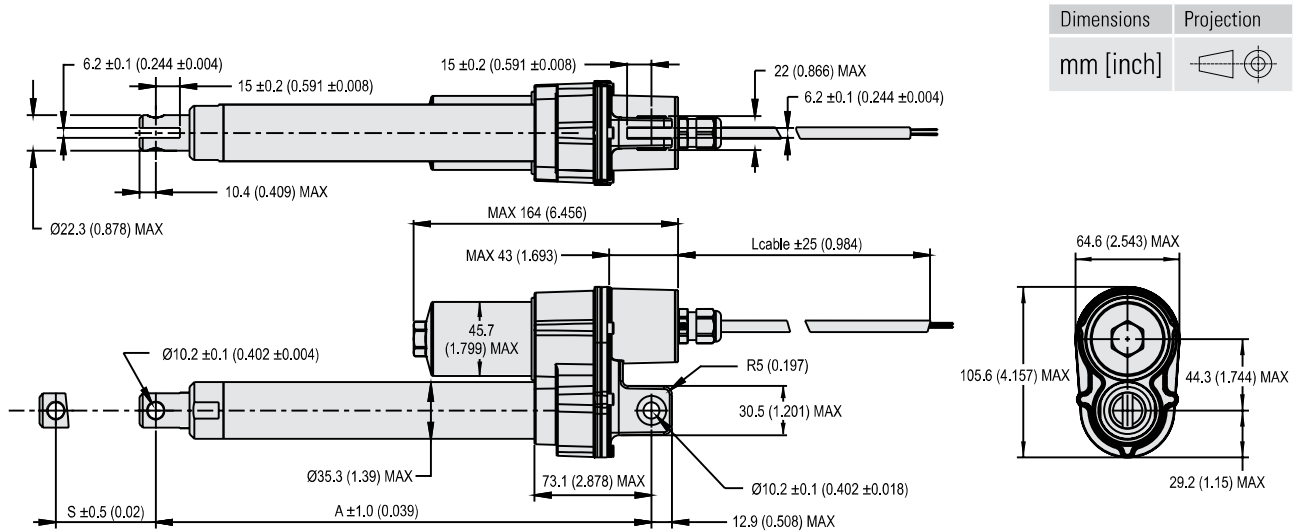

Stroke, Retracted Length and Weight Relationships

Ordering stroke (S)	[mm]	50	100	150	200	250*	300*
Retracted length (A)	[mm]	206	256	306	356	406	456
	[in]	8.11	10.08	12.05	14.02	15.98	17.95
Weight	[kg]	1.5	1.7	1.9	2.1	2.2	2.4
	[lbf]	3.3	3.8	4.2	4.6	4.8	5.3

* Stroke not possible for MSxxW1 (worm screw) models.

Max Jac[®] – Performance Diagrams

Speed and Current vs. Load

Worm Screw Models (MXxxW)

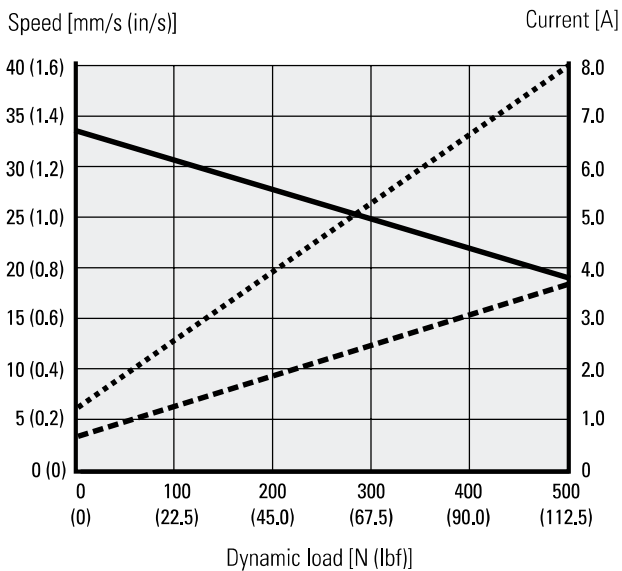

Ball Screw Models (MXxxB)

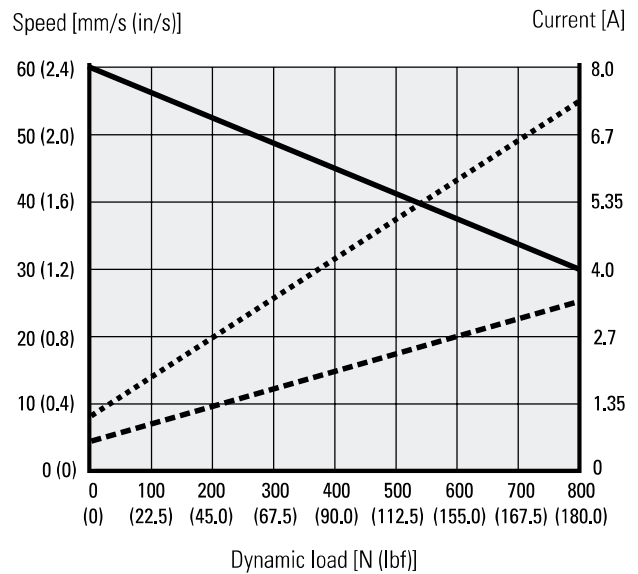

Speed ——— Current @ 12 Vdc Current @ 24 Vdc - - - - -

Duty Cycle vs. Load

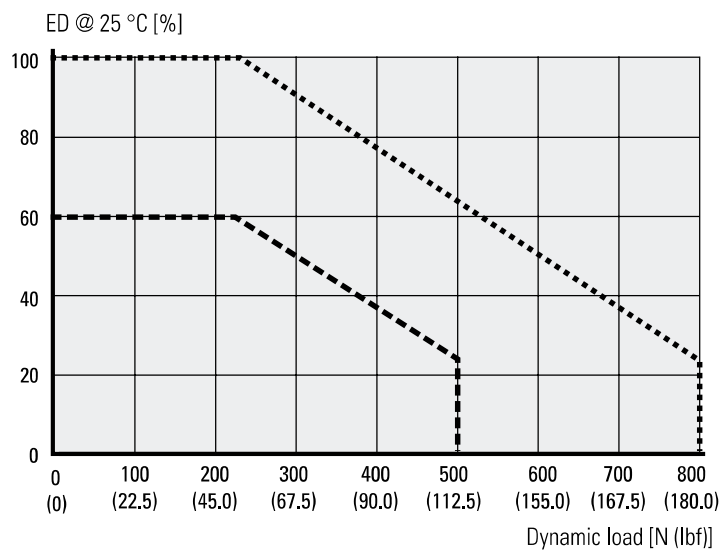

Worm Screw Models (MXxxW) - - - - - Ball Screw Models (MXxxB)



Max Jac[®] – Ordering Key

Ordering Key				
1	2	3	4	5
MX12-	W1	M05	P	0
<p>1. Model and input voltage MX12- = Max Jac, 12 Vdc MX24- = Max Jac, 24 Vdc</p> <p>2. Dynamic load capacity, screw type and maximum speed W1 = 500 N (112 lbf), worm screw, 35 mm/s (1.38 in/s) B8 = 800 N (180 lbf), ball screw, 55 mm/s (2.17 in/s)</p> <p>3. Ordering stroke length M05 = 50 mm (1.969 in) M10 = 100 mm (3.937 in) M15 = 150 mm (5.906 in) M20 = 200 mm (7.874 in) M25 = 250 mm (9.843 in)⁽¹⁾ M30 = 300 mm (11.811 in)⁽¹⁾</p>		<p>4. Options P = analog feedback (standard) E = digital encoder feedback</p> <p>5. Connector option 0 = 300 mm (12 in) long flying leads 1 = 300 mm (12 in) long cable and AMP Superseal connector 2 = 1600 mm (63 in) long cable and AMP Superseal connector</p> <p>(1) Stroke not possible for MSxxW1 (worm screw) models.</p>		

Max Jac® – Electrical Connections

Option Analog Feedback		
Actuator supply voltage	[Vdc]	
MX12		12
MX24		24
Analog feedback type		non-contact
Analog feedback input voltage	[Vdc]	5
Analog feedback output voltage	[Vdc]	0.5 - 4.5
Analog feedback output linearity	[%]	± 1

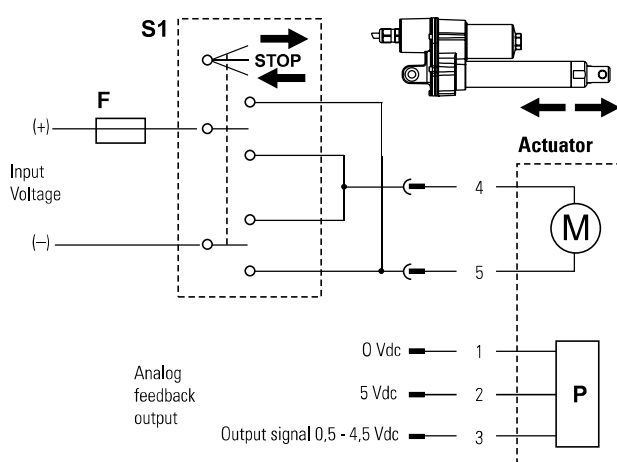

- M Actuator motor
- S1 Double pole double throw (DPDT) switch
- F Fuse
- P Analog feedback device

Connect lead 5 to positive and 4 to negative to extend the actuator. Change polarity to retract the actuator. The analog feedback device is supplied between leads 1 and 2, and the output signal is generated on lead 3.

Keep in mind that the actuator voltage must be switched off when reaching the ends of stroke or due to a mid-stroke overload to avoid causing damage to the actuator.

Option Encoder Feedback		
Actuator supply voltage	[Vdc]	
MX12		12
MX24		24
Encoder type		incremental
Number of encoder channels		2
Encoder input voltage	[Vdc]	5
Encoder output resolution	[pulse/mm]	
MX12W		9.86
MX12B		5.84

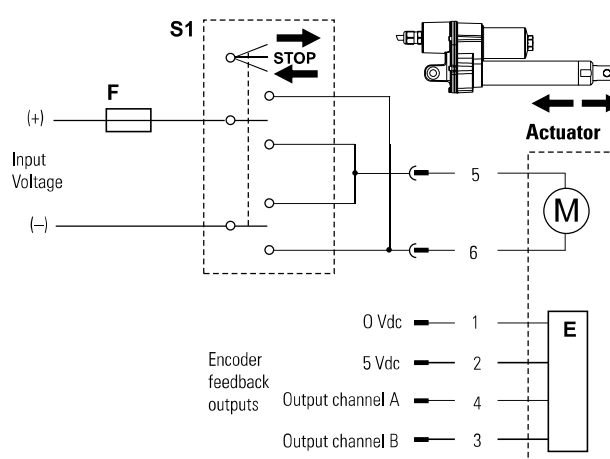

- M Actuator motor
- S1 Double pole double throw (DPDT) switch
- F Fuse
- E Encoder feedback device

Connect lead 6 to positive and 5 to negative to extend the actuator. Change polarity to retract the actuator. The encoder feedback device is supplied between leads 1 and 2, and the output signal train from channel A is generated on lead 4 and channel B on lead 3.

Keep in mind that the actuator voltage must be switched off when reaching the ends of stroke or due to a mid-stroke overload to avoid causing damage to the actuator.